

BuckCool's EZ CONNECT HEAT PUMP SYSTEM

Owner's Manual & Installation Manual



COVERS MODELS

UB1MSHCW12/UB1MSHQCO12

UB1MSHCW18/UB1MSHQCO18

UB1MSHCW24/UB1MSHQCO24

UB1MSHQCO36/UB1MSHCW36

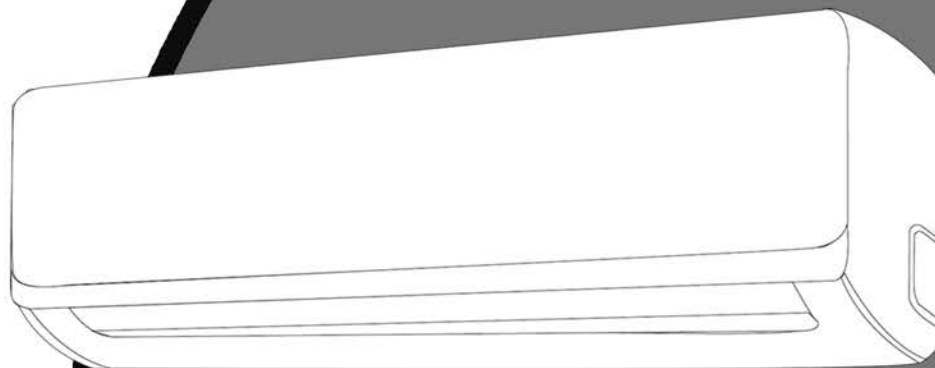

IMPORTANT NOTICE:

Read this manual carefully before installing or operating your new Heat pump unit. Make sure to save this manual for future reference.

INSTRUCTION MANUAL

BUCKCOOL EZ-CONNECT HEAT PUMP SYSTEM

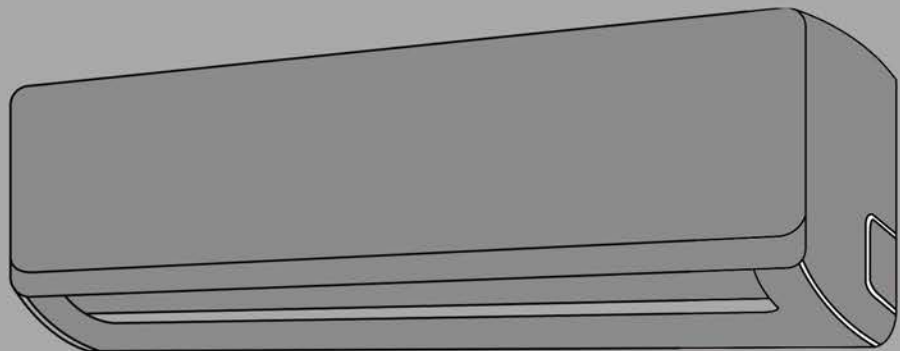

IMPORTANT NOTE:

Read this manual carefully before installing or operating your new air conditioning unit. Make sure to save this manual for future reference.

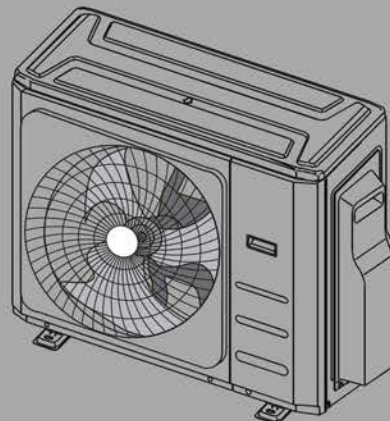

BROCK AIR PRODUCTS

2331 WEST STATE ROUTE 55 TROY, OHIO 45373
PHONE (937) 335-2626 FAX (937) 339-2776

TABLE OF CONTENTS



Title page.....02
safety precautions.....03

OWNERS MANUAL

Tools required.....07
Getting Started.....08
Parts Included.....09

INSTALLATION MANUAL

Installation.....11
Electrical Connections.....16
Diagram.....17

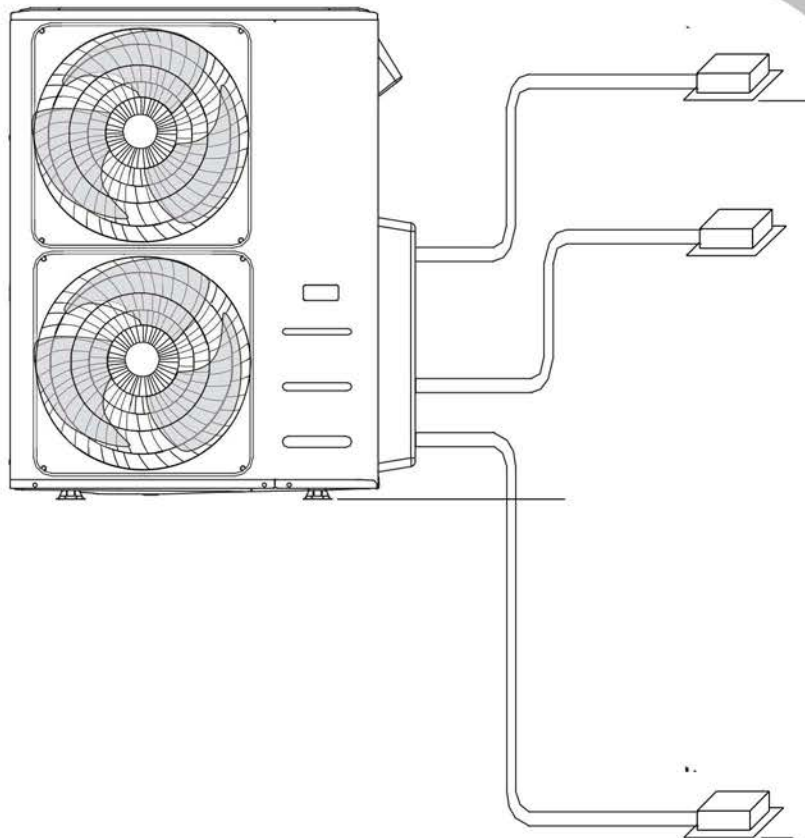

Safety Precautions

Read Safety Precautions Before Operation and Installation

Incorrect installation due to ignoring instructions can cause serious damage or injury. The seriousness of potential damage or injuries is classified as either a **WARNING** or **CAUTION**.



WARNING

This symbol indicates the possibility of personnel injury or loss of life.



CAUTION

This symbol indicates the possibility of property damage or serious consequences.



WARNING

This appliance can be used by children aged from 8 years and above and persons with reduced physical, sensory or mental capabilities or lack of experience and knowledge if they have been given supervision or instruction concerning use of the appliance in a safe way and understand the hazards involved. Children shall not play with the appliance. Cleaning and user maintenance shall not be made by children without supervision.

This appliance is not intended for use by persons (including children) with reduced physical, sensory or mental capabilities, or lack of experience and knowledge, unless they have been given supervision or instruction concerning use of the appliance by a person responsible for their safety. Children should be supervised to ensure that they do not play with the appliance.



WARNINGS FOR PRODUCT USE

- If an abnormal situation arises (like a burning smell), immediately turn off the unit and disconnect the power. Call your dealer for instructions to avoid electric shock, fire or injury.
- **Do not** insert fingers, rods or other objects into the air inlet or outlet. This may cause injury, since the fan may be rotating at high speeds.
- **Do not** use flammable sprays such as hair spray, lacquer or paint near the unit. This may cause fire or combustion.
- **Do not** operate the air conditioner in places near or around combustible gases. Emitted gas may collect around the unit and cause explosion.
- **Do not** operate your air conditioner in a wet room such as a bathroom or laundry room. Too much exposure to water can cause electrical components to short circuit.
- **Do not** expose your body directly to cool air for a prolonged period of time.
- **Do not** allow children to play with the air conditioner. Children must be supervised around the unit at all times.
- If the air conditioner is used together with burners or other heating devices, thoroughly ventilate the room to avoid oxygen deficiency.
- In certain functional environments, such as kitchens, server rooms, etc., the use of specially designed air-conditioning units is highly recommended.

CLEANING AND MAINTENANCE WARNINGS

- Turn off the device and disconnect the power before cleaning. Failure to do so can cause electrical shock.
- **Do not** clean the air conditioner with excessive amounts of water.

CLEANING AND MAINTENANCE WARNINGS

- **Do not** clean the air conditioner with combustible cleaning agents. Combustible cleaning agents can cause fire or deformation.

CAUTION

- Turn off the air conditioner and disconnect the power if you are not going to use it for a long time.
- Turn off and unplug the unit during storms.
- Make sure that water condensation can drain unhindered from the unit.
- **Do not** operate the air conditioner with wet hands. This may cause electric shock.
- **Do not** use device for any other purpose than its intended use.
- **Do not** climb onto or place objects on top of the outdoor unit.
- **Do not** allow the air conditioner to operate for long periods of time with doors or windows open, or if the humidity is very high.

ELECTRICAL WARNINGS

- Only use the specified power cord. If the power cord is damaged, it must be replaced by the manufacturer, its service agent or similarly qualified persons in order to avoid a hazard.
- Keep power plug clean. Remove any dust or grime that accumulates on or around the plug. Dirty plugs can cause fire or electric shock.
- **Do not** pull power cord to unplug unit. Hold the plug firmly and pull it from the outlet. Pulling directly on the cord can damage it, which can lead to fire or electric shock.
- **Do not** modify the length of the power supply cord or use an extension cord to power the unit.
- **Do not** share the electrical outlet with other appliances. Improper or insufficient power supply can cause fire or electrical shock.
- The product must be properly grounded at the time of installation, or electrical shock may occur.
- For all electrical work, follow all local and national wiring standards, regulations, and the Installation Manual. Connect cables tightly, and clamp them securely to prevent external forces from damaging the terminal. Improper electrical connections can overheat and cause fire, and may also cause shock. All electrical connections must be made according to the Electrical Connection Diagram located on the panels of the indoor and outdoor units.
- All wiring must be properly arranged to ensure that the control board cover can close properly. If the control board cover is not closed properly, it can lead to corrosion and cause the connection points on the terminal to heat up, catch fire, or cause electrical shock.
- If connecting power to fixed wiring, an all-pole disconnection device which has at least 3mm clearances in all poles, and have a leakage current that may exceed 10mA, the residual current device(RCD) having a rated residual operating current not exceeding 30mA, and disconnection must be incorporated in the fixed wiring in accordance with the wiring rules.

TAKE NOTE OF FUSE SPECIFICATIONS

The air conditioner's circuit board (PCB) is designed with a fuse to provide overcurrent protection.

The specifications of the fuse are printed on the circuit board ,such as :

T20A/250VAC(for <24000Btu/h unit), T30A/250VAC(for >24000Btu/h unit)

NOTE: For the units with R32 or R290 refrigerant , only the blast-proof ceramic fuse can be used.

WARNINGS FOR PRODUCT INSTALLATION

1. Installation must be performed by an authorized dealer or specialist. Defective installation can cause water leakage, electrical shock, or fire.

WARNINGS FOR PRODUCT INSTALLATION

2. Installation must be performed according to the installation instructions. Improper installation can cause water leakage, electrical shock, or fire.
(In North America, installation must be performed in accordance with the requirement of NEC and CEC by authorized personnel only.)
3. Contact an authorized service technician for repair or maintenance of this unit. This appliance shall be installed in accordance with national wiring regulations.
4. Only use the included accessories, parts, and specified parts for installation. Using non-standard parts can cause water leakage, electrical shock, fire, and can cause the unit to fail.
5. Install the unit in a firm location that can support the unit's weight. If the chosen location cannot support the unit's weight, or the installation is not done properly, the unit may drop and cause serious injury and damage.
6. Install drainage piping according to the instructions in this manual. Improper drainage may cause water damage to your home and property.
7. For units that have an auxiliary electric heater, **do not** install the unit within 1 meter (3 feet) of any combustible materials.
8. **Do not** install the unit in a location that may be exposed to combustible gas leaks. If combustible gas accumulates around the unit, it may cause fire.
9. Do not turn on the power until all work has been completed.
10. When moving or relocating the air conditioner, consult experienced service technicians for disconnection and reinstallation of the unit.
11. How to install the appliance to its support, please read the information for details in "indoor unit installation" and "outdoor unit installation" sections .

Note about Fluorinated Gasses(Not applicable to the unit using R290 Refrigerant)

1. This air-conditioning unit contains fluorinated greenhouse gasses. For specific information on the type of gas and the amount, please refer to the relevant label on the unit itself or the "Owner's Manual - Product Fiche " in the packaging of the outdoor unit. (European Union products only).
2. Installation, service, maintenance and repair of this unit must be performed by a certified technician.
3. Product uninstallation and recycling must be performed by a certified technician.
4. For equipment that contains fluorinated greenhouse gases in quantities of 5 tonnes of CO₂ equivalent or more, but of less than 50 tonnes of CO₂ equivalent, If the system has a leak-detection system installed, it must be checked for leaks at least every 24 months.
5. When the unit is checked for leaks, proper record-keeping of all checks is strongly recommended.

WARNING for Using R32 Refrigerant

- When flammable refrigerants are utilized, appliance shall be stored in a well-ventilated area where the room size corresponds to the room area as specified for operation.
For R32 refrigerant models:
Appliance shall be installed, operated and stored in a room with a floor area larger than X m² .
Appliance shall not be installed in an unventilated space, if that space is smaller than X m² .
(Please see the following form).

Amount of refrigerant to be charged (kg)	Installation height (m)	Minimum room area (m ²)	Amount of refrigerant to be charged (kg)	Installation height (m)	Minimum room area (m ²)
1.0	0.6 /1.8 /2.2	9 /1 /1	1.95	0.6 /1.8 /2.2	33 /4 /2.5
1.05	0.6 /1.8 /2.2	9.5 /1.5 /1	2.0	0.6 /1.8 /2.2	34.5 /4 /3
1.1	0.6 /1.8 /2.2	10.5 /1.5 /1	2.05	0.6 /1.8 /2.2	36 /4 /3
1.15	0.6 /1.8 /2.2	11.5 /1.5 /1	2.1	0.6 /1.8 /2.2	38 /4.5 /3
1.2	0.6 /1.8 /2.2	12.5 /1.5 /1	2.15	0.6 /1.8 /2.2	40 /4.5 /3
1.25	0.6 /1.8 /2.2	13.5 /1.5 /1	2.2	0.6 /1.8 /2.2	41.5 /5 /3.5
1.3	0.6 /1.8 /2.2	14.5 /2 /1.5	2.25	0.6 /1.8 /2.2	43.5 /5 /3.5
1.35	0.6 /1.8 /2.2	16 /2 /1.5	2.3	0.6 /1.8 /2.2	45.5 /5 /3.5
1.4	0.6 /1.8 /2.2	17 /2 /1.5	2.35	0.6 /1.8 /2.2	47.5 /5.5 /4
1.45	0.6 /1.8 /2.2	18 /2 /1.5	2.4	0.6 /1.8 /2.2	49.5 /5.5 /4
1.5	0.6 /1.8 /2.2	19.5 /2.5 /1.5	2.45	0.6 /1.8 /2.2	51.5 /6 /4
1.55	0.6 /1.8 /2.2	21 /2.5 /2	2.5	0.6 /1.8 /2.2	54 /6 /4
1.6	0.6 /1.8 /2.2	22 /2.5 /2	2.55	0.6 /1.8 /2.2	56 /6.5 /4.5
1.65	0.6 /1.8 /2.2	23.5 /3 /2	2.6	0.6 /1.8 /2.2	58 /6.5 /4.5
1.7	0.6 /1.8 /2.2	25 /3 /2	2.65	0.6 /1.8 /2.2	60.5 /7 /4.5
1.75	0.6 /1.8 /2.2	26.5 /3 /2	2.7	0.6 /1.8 /2.2	63 /7 /5
1.8	0.6 /1.8 /2.2	28 /3.5 /2.5	2.75	0.6 /1.8 /2.2	65 /7.5 /5
1.85	0.6 /1.8 /2.2	29.5 /3.5 /2.5	2.8	0.6 /1.8 /2.2	67.5 /7.5 /5
1.9	0.6 /1.8 /2.2	31 /3.5 /2.5	2.85	0.6 /1.8 /2.2	70 /8 /5.5

- Reusable mechanical connectors and flared joints are not allowed indoors. (EN Standard Requirements).
- Mechanical connectors used indoors shall have a rate of not more than 3g/year at 25% of the maximum allowable pressure. When mechanical connectors are reused indoors, sealing parts shall be renewed. When flared joints are reused indoors, the flare part shall be re-fabricated. (UL Standard Requirements)
- When mechanical connectors are reused indoors, sealing parts shall be renewed. When flared joints are reused indoors, the flare part shall be re-fabricated. (IEC Standard Requirements)
- Mechanical connectors used indoors shall comply with ISO 14903.

THANK YOU FOR YOUR PURCHASE OF THE BUCKCOOL EZ-CONNECT HEAT PUMP SYSTEM. THE EZ-CONNECT SYSTEM REQUIRES NO SPECIALIZED HVAC TOOLS SUCH AS REFRIGERANT GAUGES OR VACUUM PUMPS TO INSTALL. BELOW IS A LIST OF BASIC HAND TOOLS YOU WILL WANT TO HAVE HANDY BEFORE GETTING STARTED.



BASIC TOOLS LIST

1. 25 FT TAPE MEASURE



2. 2 FT LEVEL



3. UTILITY KNIFE



4. #2 PHILIPS SCREWDRIVER



5. 5MM ALLEN KEY



6. NEEDLE NOSE PLIERS



7. STANDARD SET OF DRILL BITS



8. CORDED OR CORDLESS DRILL



9. 3.5" HOLE SAW WITH ARBOR BIT



10. (2) 8" ADJUSTABLE WRENCHES



11. SPRAY BOTTLE FOR SOAPY WATER SOLUTION



THINGS TO CHECK BEFORE GETTING STARTED

1. The circuit breaker is the appropriate size and type for the equipment being installed. Refer to the label on the outdoor unit for specifications.
2. The circuit breaker is in the off position before attempting to install the system. Power to the equipment should never be live while attempting to install or adjusting the system.
3. The Gray and Blue refrigerant caps are intact on the indoor unit, outdoor unit, and lineset connections. If caps are missing, please stop and contact us immediately.

UNBOXING THE EQUIPMENT

INDOOR SECTION

When unboxing the indoor section, make sure to check for any physical damage to the air handler. Also make sure the connection cable is intact and physically connected to the air handler.

If the air handler section is damaged or the connection cable is disconnected/missing, please stop immediately and give us a call.

IMPORTANT

BEFORE THROWING AWAY THE BOX, BE SURE TO REMOVE THE CARDBOARD TEMPLATE FOR SECURING THE AIR HANDLER TO THE WALL. WITHOUT THE TEMPLATE, INSTALLATION WILL BE MORE DIFFICULT.

INCLUDED IN INDOOR SECTION BOX WILL BE A CONTENTS BAG OF MIXED PARTS.

THE PARTS BAG SHOULD INCLUDE THE FOLLOWING



1. NetHome Plus Wi-Fi Adapter – Used for connecting the BuckCool EZ-Connect Heat Pump system to your Wi-Fi network.
2. Handheld Remote Control – Used for temperature control of the BuckCool EZ-Connect Heat Pump system.
3. Remote Wall Bracket – Used for mounting the Handheld Remote Control in a convenient location.
4. Mounting Hardware – Screws and Wall Anchors (x5) Used for securing the mounting plate of the indoor unit to the interior wall.
5. batteries (x2) – Used for powering Handheld Remote Controller
6. Drain Joint – Used to drain excess condensation water away from the outdoor condenser.
7. Foam insulation (x2) – Used for wrapping joints where the EZ-Connect lineset will meet the indoor air handler factory piping connections.
8. Tar Tape (x2)- Used for wrapping joints where the EZ-Connect lineset will meet the indoor air handler factory piping connections. Helps with vibration noise reduction.
9. Remote Control & Owners Manuals – Used for system control and future reference material.

OUTDOOR SECTION

WHEN UNBOXING THE OUTDOOR SECTION, MAKE SURE THE TO CHECK FOR ANY PHYSICAL DAMAGE TO THE CONDENSER.

IF THE CONDENSER SECTION IS DAMAGED, PLEASE STOP IMMEDIATELY AND GIVE US A CALL.



IMPORTANT

INCLUDED IN INDOOR SECTION BOX WILL BE A CONTENTS BAG OF MIXED PARTS. THE PARTS BAG SHOULD INCLUDE THE FOLLOWING.

1. 25ft Refrigerant Lineset – Used for connecting the indoor air handler to the outdoor condenser.
2. Vibration Pads (x4)- Used for reducing vibration noise between outdoor condenser and the mounting surface.
3. Drain Tubing- Used for connecting to the factory drain tubing to remove condensation from the indoor air handler
4. Wall Sleeve- Used for protecting the refrigerant lines, communication cable, and drain tubing as it is passed through the wall.
5. Beauty Cap- Used for capping of the hole drilled for the refrigerant lines, communication cable, and drain tubing on the outside portion of the home.
6. UV Tape (x3)- Used for bundling the lineset, communication cable, and drain tubing before it is passed through the outside wall.

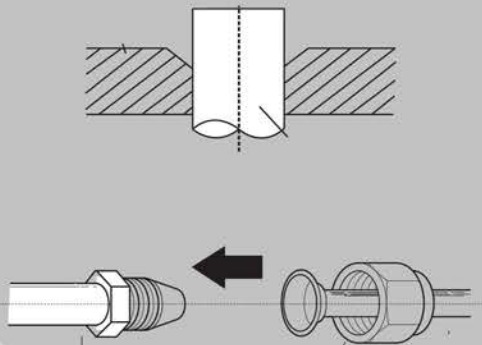

Installation

1. Choose a location where the indoor unit will be installed. Pick a location that has at least 6" of clearance from the top of the ceiling and 5" from each side of the air handler. Make sure the installation location is not in direct sunlight, away from any obstacles that may block air circulation, and at least 3ft away from any other electronic devices.
2. Locate the cardboard wall template included with the indoor air handler. Using a level, make sure the template is straight and level before attaching to the wall.



3. Using painters tape, attach the template to the wall the air handler will be installed on.
4. Using the template, mark and drill the holes for the mounting plate to attach to the wall. Also mark and drill the center point for the 3.5 hole to the outside. When drilling through the wall, drill at a slight downward angle to help pass through the lineset, communication wire, and drain tubing bundle.
5. Remove the wall template.
6. Locate the metal wall bracket attached to the backside of the indoor air handler. From the factory, it is attached to the air handler with a sheet metal screw. The screw is located near the center of the air handler. Remove the screw and wall bracket from the air handler.
7. Using the included mounting hardware, install the wall anchors and screw the wall bracket into the predrilled holes in Step 4.
8. Pass the wall sleeve through the wall from inside to outside. From the outside, mark the wall sleeve where it meets the outside wall. Remove the wall sleeve from the inside and cut the sleeve down to size at the location just marked. This will make a flush fit for the wall sleeve and allow for the outdoor beauty cap to be installed on the outside wall.
9. Reinstall the wall sleeve from the inside of the wall opening.
10. On the indoor air handler, locate the refrigerant line and drain tubing connections on the back side of the unit. Carefully bend the connections outward to prepare them to pass through the wall.

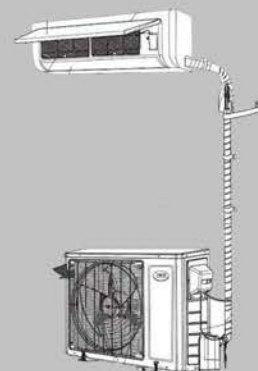
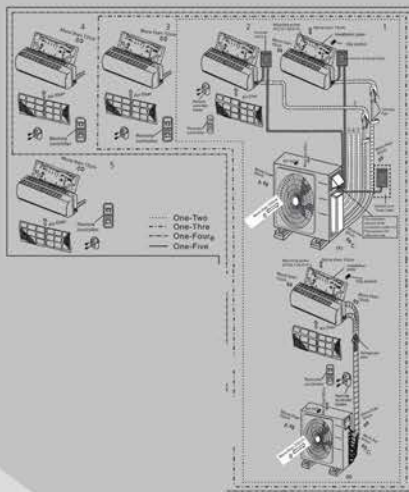

11. Bundle together the communication cable, refrigerant lineset connections, and drain tubing connection for preparing to pass it through the wall. Wrap the bundle together using the UV tape provided with the air handler. This will protect the bundle and make sure it passes easily through the wall sleeve.



IMPORTANT - Use two hands when bending out the refrigerant lines, one hand near the base of the connections to brace the factory connections and one hand to bend the lineset. This will prevent the copper from kinking as it is being bent.

IMPORTANT - Make sure the drain tubing is located at the bottom of the bundle. This will allow for better drainage and ensure no water backs up into the indoor air handler.

12. Prepare to mount the indoor unit to the wall bracket. Carefully pass the bundle through the wall making sure the drain tubing stays to the bottom of the bundle. Place the top section of the air handler on to the bracket first, making sure to catch the clips on the wall bracket to the air handler itself. Once the top clips are in place, press down on the air handler to lock the bottom to the wall bracket.

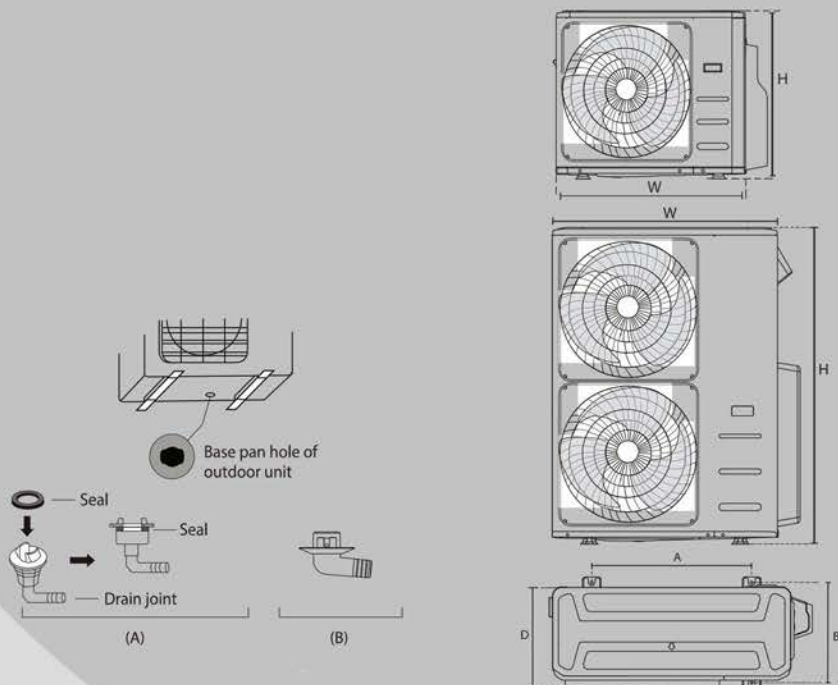

IMPORTANT - THIS MAY BE DIFFICULT FOR A SINGLE PERSON TO MANAGE. IF YOU HAVE A HELPER AVAILABLE, IT WOULD BE BEST TO HAVE THEM HELP BALANCE OUT THE UNIT AS THE LINE BUNDLE IS BEING PASSED THROUGH THE WALL.

13. From the outside, pass the beauty cover for the wall through the lineset bundle and push into place.
14. Carefully bend the bundle down the outside wall. Use two hands when bending the copper connections like in step 10.

IMPORTANT - ONE HAND TO BRACE THE COPPER AS CLOSE TO THE OUTSIDE WALL AS POSSIBLE AND ONE HAND TO BEND THE COPPER ITSELF. THIS WILL PREVENT THE COPPER FROM KINKING AS IT IS BEING BENT DOWN THE WALL.

15. Attach the drain tubing extension, provided with the outdoor unit supply bag, to the factory drain tubing connection. Route the drain tubing down the wall to a location where the excess drainage water will not be an issue.

LINESET CONNECTIONS

16. Locate the refrigerant lineset provided with the outdoor unit. On a flat, level surface, carefully unroll the lineset to prepare and install at the factory connections for the indoor unit just passed through the wall.
17. On the factory piping connections that were passed through the wall, remove the gray and blue caps so you can prepare to install the lineset. On one end of the lineset, also remove the gray and blue caps. Leave the other ends capped that will be connected to the outdoor condenser.
18. Line up the factory connections to the lineset fittings. Hand tighten the first few threads and use the adjustable wrenches to tighten down the rest. Tighten until all the threads can't be seen, and the fittings are bottomed out together.

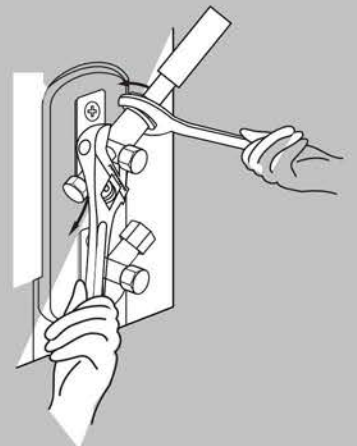

LINESET CONNECTIONS

IMPORTANT – BE SURE TO USE TWO WRENCHES WHEN TIGHTENING THE FITTINGS, ONE TO BACK UP THE FACTORY CONNECTION, AND ONE TO SCREW THE LINESET SIDE TOGETHER. THIS WILL PREVENT THE COPPER FROM TWISTING AND BREAKING DURING INSTALLATION.

19. Set the outdoor condenser in place. Pick a location that has no airflow obstructions for the outdoor unit. Make sure no combustible materials will be within proximity of the unit.



IMPORTANT -MAKES SURE IF THE UNIT IS BEING MOUNTED TO A WALL BRACKET, IT HAS 6" OF CLEARANCE FROM THE BACK OF THE UNIT TO THE WALL, 12" AROUND EACH SIDE, AND 80" FROM THE FRONT DISCHARGE FAN TO ENSURE PROPER OPERATION.

IF MOUNTING THE OUTDOOR TO A UNIT TO A GROUND PAD, MAKE SURE THE SURFACE IS FLAT AND LEVEL. ON GROUND LEVEL INSTALLS, MAKE SURE THE UNIT HAS 12" OF CLEARANCE FROM THE BACK OF THE UNIT TO THE WALL, 12" AROUND EACH SIDE, AND 80" FROM THE FRONT DISCHARGE FAN TO ENSURE PROPER OPERATION.

20. Remove the Gray and Blue caps on the other end of the refrigerant lineset not installed yet. Also remove the Gray and Blue caps at the connection ports for the outdoor condenser.
21. Repeat Step 18 at the outdoor condenser. Line up the condenser connections to the lineset fittings. Hand tighten the first few threads and use the adjustable wrenches to tighten down the rest. Tighten unit all the threads can't be seen, and the fittings are bottomed out together.

IMPORTANT – BE SURE TO USE TWO WRENCHES WHEN TIGHTENING THE FITTINGS, ONE TO BACK UP THE CONDENSER CONNECTION, AND ONE TO SCREW THE LINESET SIDE TOGETHER. THIS WILL PREVENT THE COPPER FROM TWISTING AND BREAKING DURING INSTALLATION.

22. Locate the brass hexagonal valve caps just above the lineset connections. Using an adjustable wrench, remove the valve caps.
23. Insert a 5 mm Allen key into the valve body assemblies. Turn the valve body counterclockwise to open the refrigerant valves. This will release the refrigerant into the system.

IMPORTANT - YOU WILL NEED TO USE A LITTLE BIT OF FORCE TO OPEN THE VALVE BODIES AND START THE THREADS. ONCE THE VALVE STARTS SPINNING, IT WILL SPIN FREELY. KEEP TURNING THE VALVES COUNTERCLOCKWISE UNTIL YOU HIT A GOOD AMOUNT OF RESISTANCE. DO NOT FORCE FURTHER. NOW THE VALVE BODY IS COMPLETELY OPEN.

DO NOT CLOSE THE VALVE BODY AFTER THE REFRIGERANT IS RELEASED. IT NEEDS TO STAY OPEN FOR PROPER UNIT OPERATION.

24. Re-install the brass hexagonal valve caps.



LEAK CHECKING SYSTEM AND FINAL LINE SET PREPARATIONS

25. Using a spray bottle, prepare a solution of soapy water to leak check the fittings. The more suds in the solution, the easier any leaks will be to find. Dish soap and water works well for this process.
26. Spray down all the refrigerant lineset connections and fittings with the soapy solution. Let the excess solution drip off the fittings and wait to see if bubbles start forming at any of the connection points. If you see bubbles, wipe the fittings down with a clean rag or paper towel and repeat the process. If bubbles form again, a leak is present.

IMPORTANT – IF A LEAK IS FOUND AND PRESENT, THE FITTINGS WILL NEED TO BE RE-TIGHTENED DOWN. AFTER RE-TIGHTENING THE FITTINGS, REPEAT THE LEAK CHECK PROCESS AGAIN UNTIL NO BUBBLES ARE PRESENT.

27. Wipe down all the soapy water solution off the fittings using a clean rag or paper towel.
28. Using the tar tape provided with the indoor air handler, wrap the factory fittings and lineset connections. Press the tar tape into place around the fittings and mold to the shape of the lineset. Cover the tar tape and fittings with the insulation material provided with the air handler.
29. Using the UV tape provided with the outdoor condenser, wrap the lineset bundle for where it exists the home down to the outdoor condenser.



ELECTRICAL CONNECTIONS

IMPORTANT – PLEASE DOUBLE CHECK AND MAKE SURE YOU HAVE THE CORRECT POWER SOURCE BEING USED FOR THE SYSTEM PURCHASED.



FOR THE 12K BTU SYSTEM, IT WILL REQUIRE A SINGLE POLE 15-AMP BREAKER, 115 VOLTS

FOR THE 18K BTU SYSTEM, IT WILL REQUIRE A DOUBLE POLE 20-AMP BREAKER, 240 VOLTS

FOR THE 24K BTU SYSTEM, IT WILL REQUIRE A DOUBLE POLE 30-AMP BREAKER, 240 VOLTS

FOR THE 36K BTU SYSTEM, IT WILL REQUIRE A DOUBLE POLE 40-AMP BREAKER, 240 VOLTS

30. THE ELECTRICAL WIRING COVER ON THE OUTDOOR CONDENSER AND PLACE OFF TO THE SIDE.
31. REMOVE THE TWO ROUND BLACK KNOCKOUTS FROM THE WIRING COVER PLATE.
32. INSTALL THE WIRE WHIP FROM THE DISCONNECT BOX USING THE RIGHT-HAND KNOCKOUT.

*FOLLOW THE DIRECTIONS IN THE WIRING DIAGRAM PROVIDED ON THE NEXT PAGE FOR YOUR SPECIFIED UNIT
33. INSTALL THE COMMUNICATIONS CABLE FROM THE INDOOR AIR HANDLER USING LEFT-HAND KNOCKOUT.



The design and specifications are subject to change without prior notice for product improvement. Consult with the sales agency or manufacturer for details.



WIRE CONNECTING DIAGRAM

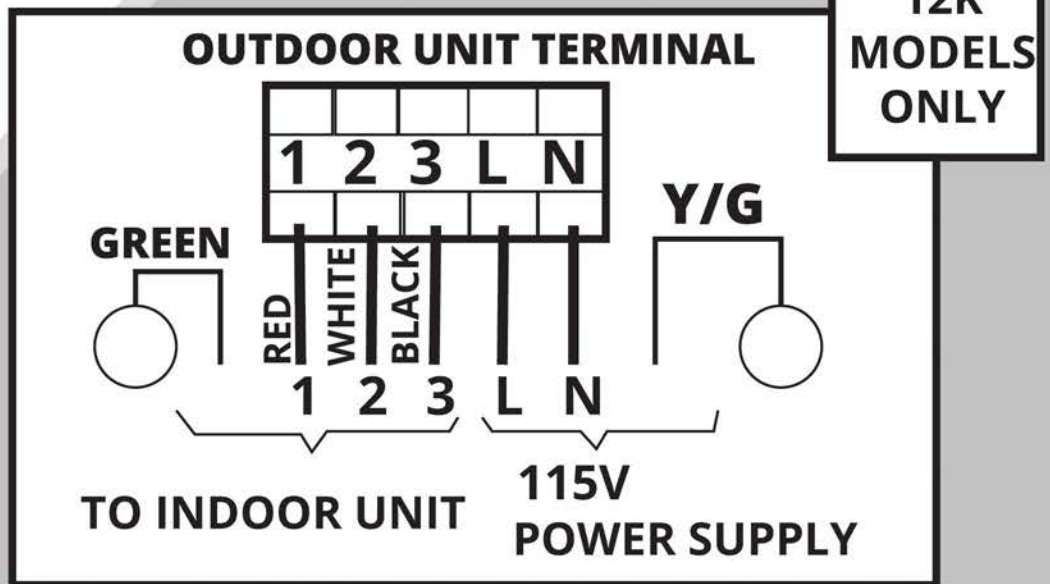

WIRE CONNECTING DIAGRAM

